

TW 400



Spare parts
Ersatzteile
Pièces détachées
Reservedele

303000060 - 2005-08-25

Nilfisk ALTO

Why Compromise

ROBE
Reinigungsmaschinen

Hotline: 0 73 03 / 901 980

Zur Aumühle 36 | 89257 Illertissen
Tel.: 0 73 03 / 901 980 | Fax 0 73 03 / 901 981 8
info@wap-nilfisk-alto-shop.de

www.wap-nilfisk-alto-shop.de

Zeichenerklärung

Key to symbols

Légende

Symbol erklæring

Recommended spare parts

A-Parts:

High turning parts. Recommended stock size is: [Number of machines sold x 0.02] or minimum 1.

These parts are typical: Brushes, brooms, flaps, filters, squeegee blades, etc.

B-Parts:

Medium turning parts. Recommended stock size is: [Number of machines sold x 0.01] or minimum 1.

These parts are typical: Hydraulic valves, fuses, circuit breakers, seal kits, belts, carbon brushes, etc.

C-Parts:

Low turning parts. Recommended stock size is: Minimum 1.

These parts are typical: Electrical parts, relays, switches, motors, hoses, wheels, etc.

Empfohlene Ersatzteile

A-Teile:

Teile mit hoher Umschlagshäufigkeit. Empfohlene Lagerstückzahl: [Anzahl der verkauften Maschinen x 0,02] oder Minimum 1.

Diese Teile sind typisch: Bürsten aller Art, Filter, Staubklappen, Gummilamellen, etc.

B-Teile:

Teile mit mittlerer Umschlagshäufigkeit. Empfohlene Lagerstückzahl: [Anzahl der verkauften Maschinen x 0,01 oder Minimum 1.

Diese Teile sind typisch: Hydraulische Ventile, Sicherungen, Stromunterbrecher, Dichtungssätze, Riemen, Kohlebürsten, etc.

C-Teile:

Teile mit niedriger Umschlagshäufigkeit. Empfohlene Lagerstückzahl: Minimum 1.

Diese Teile sind typisch: Elektrische Teile, Relais, Schalter, Motoren, Schläuche, Räder, etc.

Liste de pièces à stocker

Pièces-A:

Pièces de rechange de la vitesse de rotation haute. Le stock conseillé est : [Nombre de machines acheteés x 0,02] avec un minimum de 1.

Classiquement, ces pièces sont : Brosses, balais, volets, filtres, raclettes, etc.

Pièces-B:

Pièces de rechange de la vitesse de rotation moyenne. Le stock conseillé est : [Nombre de machines acheteés x 0,01] avec un minimum de 1.

Classiquement, ces pièces sont : Hydrauliques, fusibles, coupe-circuits, kits joints, courroies, charbons, etc.

Pièces-C:

Pièces de rechange de la vitesse de rotation bas. Le stock conseillé est : Un minimum de 1.

Classiquement, ces pièces sont : Pièces électriques, relais, interrupteurs, moteurs, flexibles, roues, etc.

Anbefalede reservedele

A-Parts:

Dele med høj omsætningshastighed. Anbefalet lagerstørrelse: [Antal maskiner solgt x 0,02] eller minimum 1.

Disse dele er typisk: Skrubbørster, fejekoste, klapper, filters, sugegummiblade, m.v.

B-Parts:

Dele med middel omsætningshastighed. Anbefalet lagerstørrelse: [Antal maskiner solgt x 0,01] eller minimum 1.

Disse dele er typisk: Hydrauliske ventiler, sikringer, automatsikringer, manchet kits, remme, kulbørster, m.v.

C-Parts:

Dele med lav omsætningshastighed. Anbefalet lagerstørrelse: Minimum 1.

Disse dele er typisk: Elektriske dele, relæer, kontakter, motorer, slanger, hjul, m.v.

- ◇ ACHTUNG! - Meterware - Bitte bei Bestellung gewünschte Länge angeben!
- ATTENTION! - Lengths in metres - Please indicate required length when ordering!
- ATTENTION! - Longueurs par mètre - Préciser la longueur à la commande!
- BEMÆRK! - Metervare - Ved bestilling venligst opgive den ønskede længde!

- * bestehend aus ● beinhaltet
- consisting of includes
- composé de inclus
- bestående af inkludere

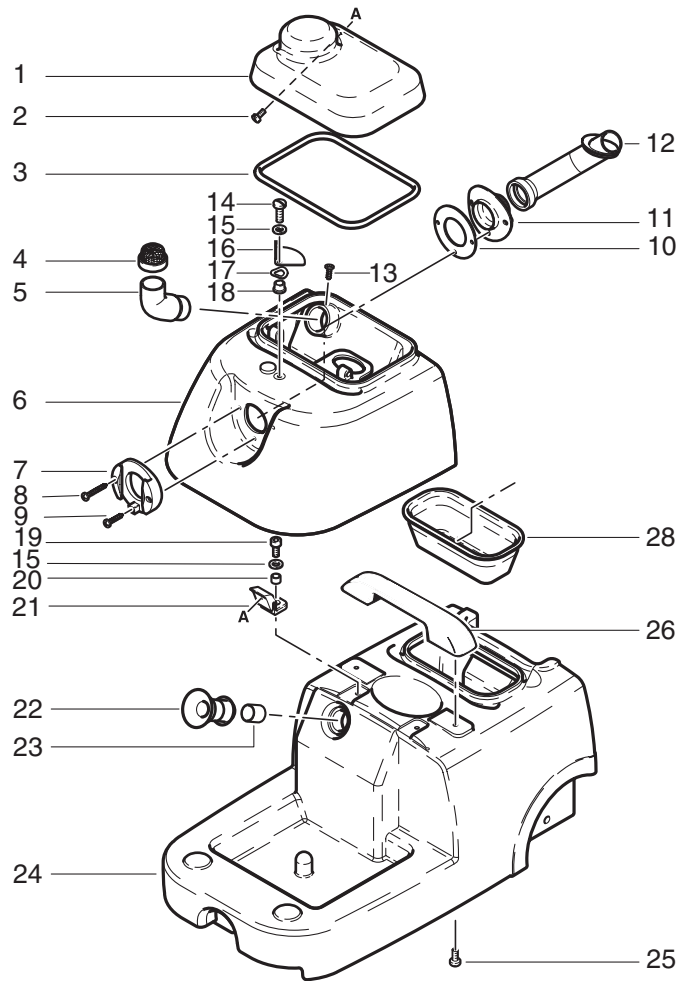

TW 400-101-S

Pos.	No.	Description	Bezeichnung	Comment Bemerkung Bemærkning	Rec. Part	TW 400
1	303000013	Cover	Haube			1
2	6350	Screw M4x6	Linsensensschraube M4x6			2
3	63727	Gasket 72x10x10	Dichtung 72x10x10			1
4	44922	Filter	Filter		C	1
5	303000017	Bent Tube Ø38	Ansaugstutzen Ø38			1
6	303000016	Waste Water Tank	Behälter Schmutzwasser			1
7	303000018	Fitting DN36	Einlassfitting DN36			1
8	40108	Sheet Metal Screw 4,8x32	Blechschrabe 4,8x32			2
9	1814276	Screw 5x30	Schraube 5x30			1
10	303000019	Gasket Ø92x48x2	Dichtung Ø92x48x2			1
11	303000020	Deviation Ø83x82x38	Flansch Ø83x82x38			1
12	63730	Pipe Bended Ø50x150x130	Rohr Gebogen Ø50x150x130			1
13	12004	Screw 2,9x6,5	Blechschrabe 2,9x6,5			1
14	2781	Screw M6x20	Zylinderschraube M6x20			1
15	2764	Washer 6,4x1,6	Scheibe 6,4x1,6			3
16	303000014	Locking Device 49x49x18	Verschlussplatte 49x49x18			1
17	32520	Washer 8,4x1,6x15	Scheibe 8,4x1,6x15			1
18	303000015	Distance Piece Ø18x6x9	Distanzbüchse Ø18x6x9			1
19	9795	Screw M5x12	Schraube M5x12			2
20	303000022	Distance Piece Ø7x5x5	Distanzbüchse Ø7x5x5			2
21	63728	Hinge 55x51x30	Scharnier 55x51x30			2
22	303000029	Seal Ø64x25x73	Dichtung Form- Ø64x25x73			1
23	303000027	Reinforcing piece Ø27x24x28	Büchse Ø27x24x28			1
24	303000025	Clean water tank	Behälter Frischwasser			1
25	11565	Screw 5x18	Schraube 5x18			2

303000060 - 2005-08-25

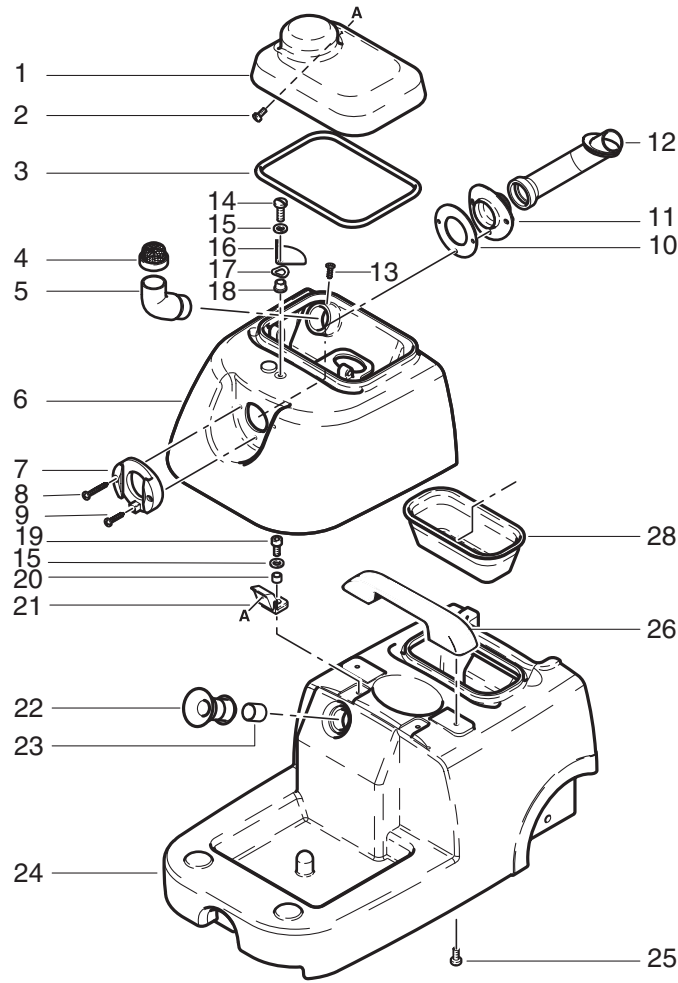

TW 400-101-S

Pos.	No.	Description	Bezeichnung	Comment Bemerkung Bemærkning	Rec. Part TW 400
26	43191	Bow-type handle	Bügelgriff		1
28	303000021	Filling funnel 210x105x75	Trichter 210x105x75		1

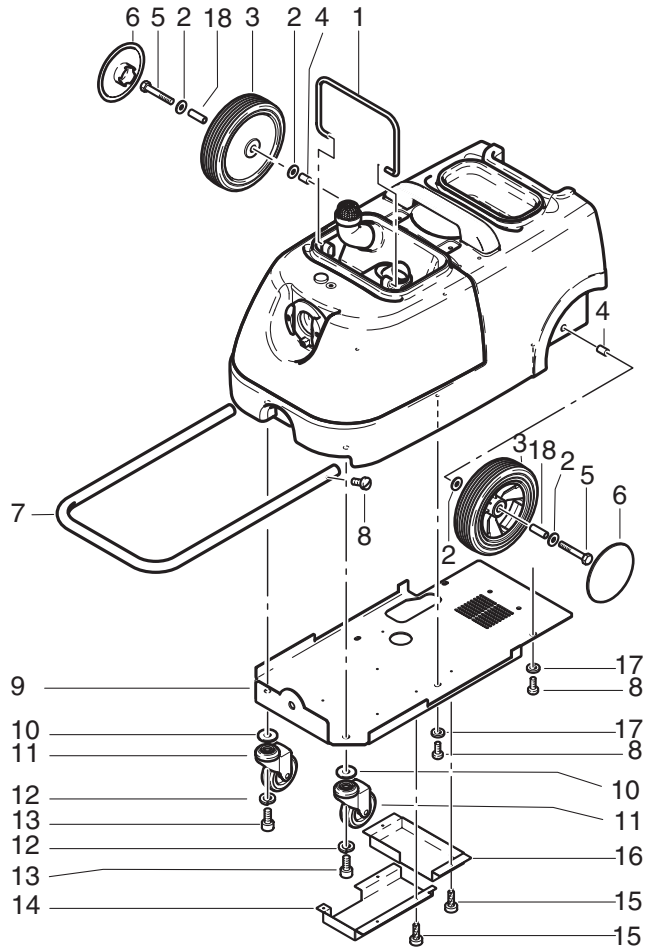

TW 400-102-S

Pos.	No.	Description	Bezeichnung	Comment Bemerkung Bemærkning	Rec. Part TW 400
1	303000028	Carrying handle	Bügel		1
2	34939	Washer 8,4x2	Scheibe 8,4x2		4
3	62421	Wheel	Rad		2
4	303000030	Distance piece	Distanzbüchse $\varnothing 12 \times 8 \times 23$		2
5	3345	Screw M8x70	Sechskantschraube M8x70		2
6	67050	Hub cap $\varnothing 115$ (Blue)	Radkappe $\varnothing 115$ (Blau)		2
7	303000032	Bow	Schubbügel		1
8	8917	Screw M6x12	Sechskantschraube M6x12		6
9	303000026	Bottom plate 602x294x70	Bodenblech 602x294x70		1
10	4827	Washer 10,5x2,5	Scheibe 10,5x2,5		2
11	61789	Guide roller	Lenkrolle		2
12	4828	Lock washer 10	Federring 10		2
13	8926	Screw M10x20	Sechskantschraube M10x20		2
14	303000024	Large air canal 200x120x25	Abluftkanal 200x120x25		1
15	27138	Screw M4x8	Schraube M4x8		6
16	303000023	Small air canal 200x82x25	Abluftkanal 200x82x25		1
17	2766	Washer 6,4x1,6	Scheibe 6,4x1,6		6
18	303000031	Distance piece $\varnothing 12 \times 8 \times 36$	Distanzbüchse $\varnothing 12 \times 8 \times 36$		2

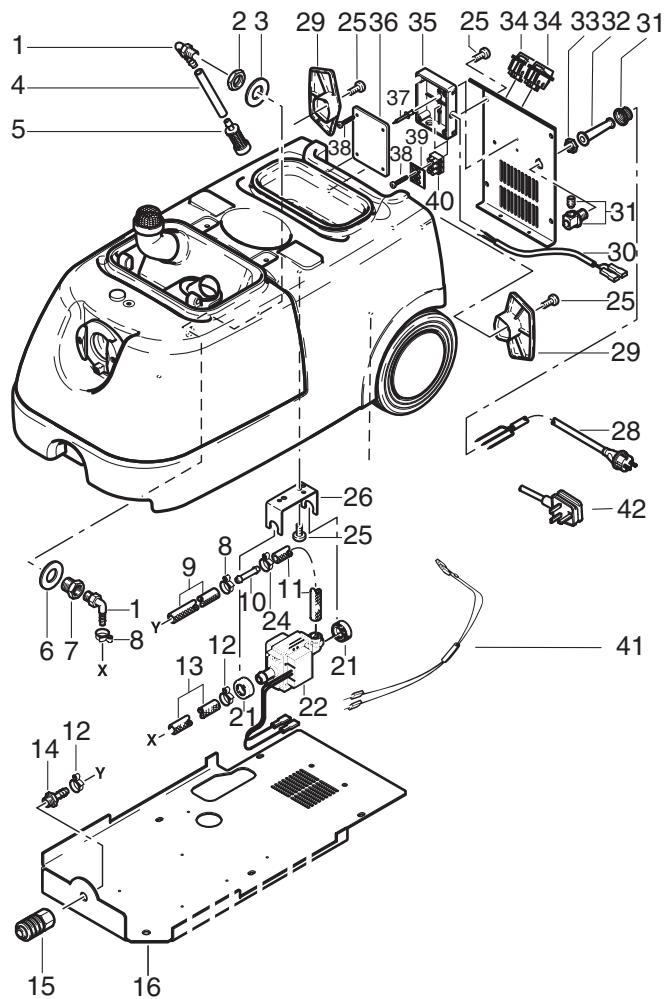

TW 400-103-S

Pos.	No.	Description	Bezeichnung	Comment Bemerkung Bemærkning	Rec. Part	TW 400
1	62411	Hose liner Ø6 G1/4	Schlauchtülle Ø6 G1/4			2
2	7393	Hexagon Nut R3/8x5	Sechskantmutter R3/8x5			1
3	7279	Packing Ring Ø17x2xØ32	Dichtring Ø17x2xØ32			1
◇	4	Hose Ø6x1	Schlauch Ø6x1			1
5	62412	Suction filter	Saugsieb		C	1
6	28134	Washer 35x24x1,5	Scheibe 35x24x1,5			1
7	28350	Red. piece 3/8-1/4"	Red-Stück 3/8-1/4"			1
8	7275	Hose clip	Schlauchklemme			2
◇	9	Hose Ø6x3	Schlauch Ø6x3			1
10	303000037	Hose coupling Ø6	Schlauchverbinder Ø6 gerade			1
◇	11	Hose Ø6x1	Schlauch Ø6x1			1
12	7239	Hose Clip Ø14,5	Schlauchschelle Ø14,5			2
◇	13	Hose Ø6x3	Schlauch Ø6x3			1
14	7355	Hose Liner Ø8 R1/4	Schlauchtülle Ø8 R1/4			1
15	303000252	Coupling IG 1/4"	Kupplung IG 1/4"			1
16	303000026	Bottom plate 602x294x70	Bodenblech 602x294x70			1
21	7385	Retaining Ring	Haltebühel			2
22	303000038	Pump 220-240V/50	Sprühpumpe 220-240V/50		C	1
24	11860	Hose Clip Ø9-11	Schlauchschelle Ø9-11			1
25	2780	Screw M6x12	Zylinderschraube M6x12			8
26	7386	Bracket	Haltebühel			1
28	14797	Power Cord H05VV-F 3G1,5x7,5	Netzleitung H05VV-F 3G1,5x7,5	*EU*		1
29	303000034	Holder	Halte			2
30	303000033	Cable	Kabelbaum 2-adrig 1,0²x260			1

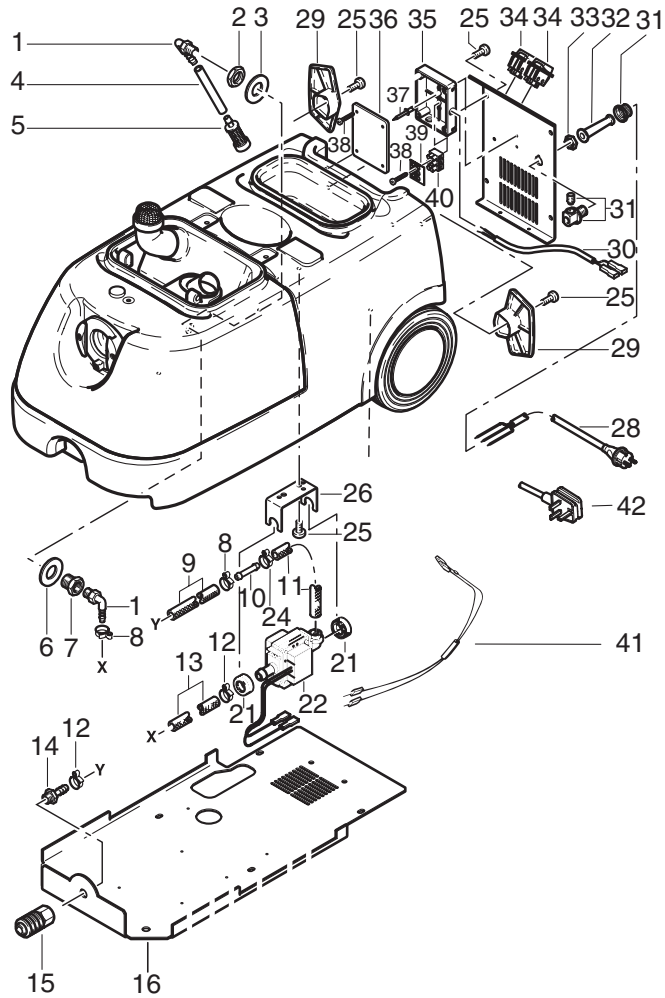

TW 400-103-S

Pos.	No.	Description	Bezeichnung	Comment Bemerkung Bemærkning	Rec. Part	TW 400
31	7309	Cable Fixation PG9	Zugentlastung PG9			1
32	7352	Cable Grommet	Knickschutztülle			1
33	1458	Nut 6KT PG 9	Sechskantmutter PG 9			1
34	303000058	Switch 10A 250VAC	Wippschalter 2-polig 10A 250VAC		C	2
35	303000036	Switch Box	Schaltkasten			1
36	303000035	Distribution box cover	Deckel			1
37	6714	Rivet 3,2x9,5	Niet 3,2x9,5			2
38	18086	Screw 2,9x13	Blechschaube 2,9x13			6
39	7146	Label	Klebeschild			1
40	7466	Terminal	Reihen клемме			1
41	7389	Cable Lead Wire w. Diode	Kabelbaum mit Diode		C	1
42	61129	Power Cord H05VV-F 3G1,5x5	Netzleitung H05VV-F 3G1,5x5	*GB*		1

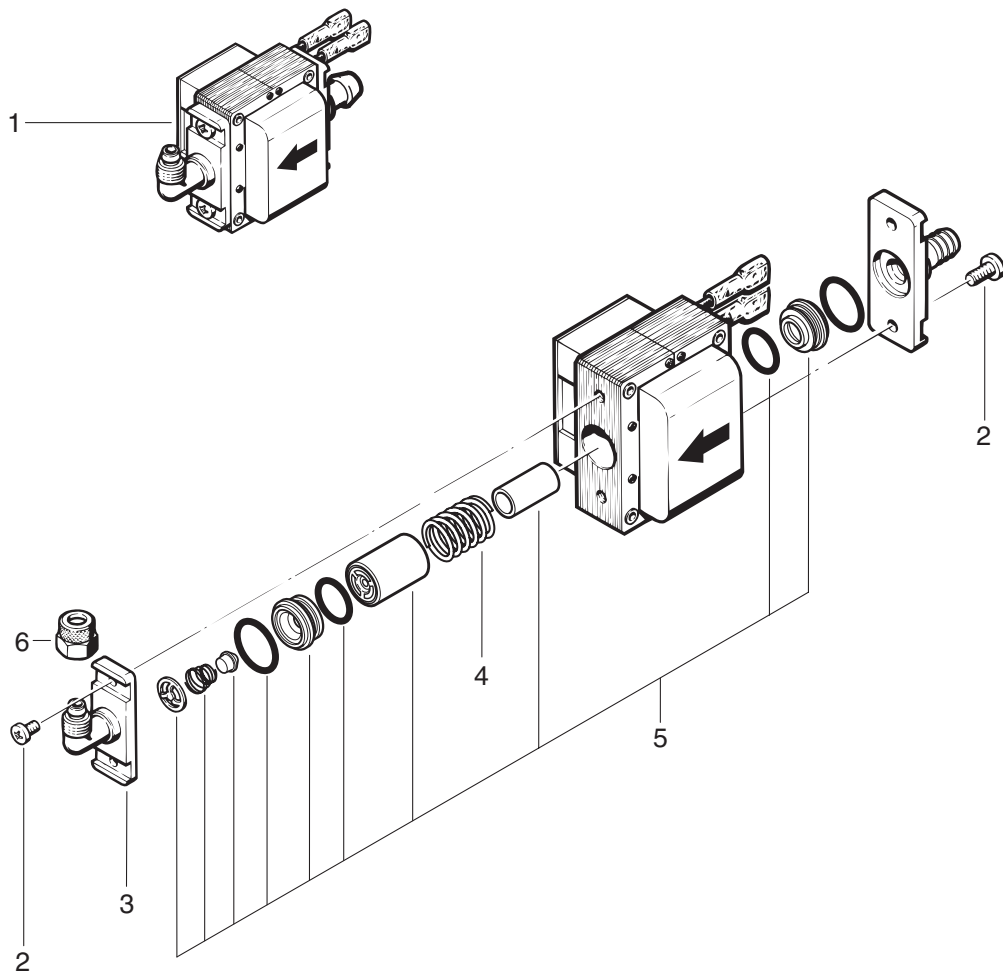

TW 400-I04-S

Pos.	No.	Description	Bezeichnung	Comment Bemerkung Remarque Bemærkning	Rec. Part TW 400
1	303000038	Pump 220-240V/50	Sprühpumpe 220-240V/50		C 1
2	46269	Screw M4x10	Flachkopfschraube M4x10		4
3	45021	Connecting flange	Flansch Anschluss-		1
4	909100089	Spring 1,7x14,6x20	Druckfeder 1,7x14,6x20		C 1
5	34049	Repair Kit	Rep.Satz Wasserpumpe		A 1
6	45023	Nut M12x10	Überwurfmutter M12x10		1

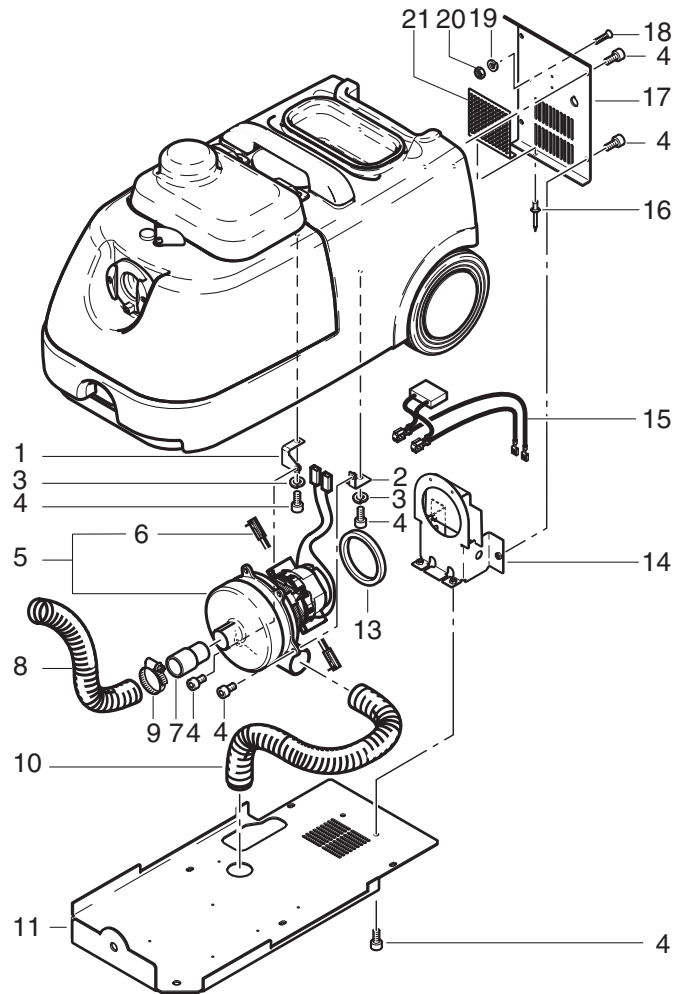

TW 400-005-S

Pos.	No.	Description	Bezeichnung	Comment Bemerkung Bemærkning	Rec. Part	
					TW 400	
1	303000044	Elbow 2x36x36x34	Winkel 2x36x36x34			1
2	303000043	Elbow 2x36x28x23	Winkel 2x36x28x23			1
3	24312	Spring washer A6	Federring A6			2
4	3913	Screw M6x12	Zylinderschraube M6x12			10
5	303000055	Motor 220/240V 1000W	Motor 220/240V 1000W		C	1
6	26775	Carbon Brush Set "L"	Kohlebürsten-Set "L"		B	1
7	303000053	Adaptor Ø39	Adapter Ø39			1
↔	8	Suction hose Ø35	Saugschlauch Ø35			1
9	7061	Hose Clip Ø32-50	Schlauchschelle Ø32-50			1
↔	10	Suction Hose Ø38	Saugschlauch Ø38			1
11	303000026	Bottom plate 602x294x70	Bodenblech 602x294x70			1
13	15712	Packing Ring 78x105x10	Dichtring 78x105x10			1
14	303000040	Plate 176x159x80	Blech 176x159x80			1
15	303000042	Cable 2x1x320	Kabelbaum 2-adrig 1x320			1
16	6714	Rivet 3,2x9,5	Niet 3,2x9,5			2
17	303000039	Control panel	Bedienfeld			1
18	3480	Screw M4x20	Senkschraube M4x20			1
19	2771	Lock washer 4	Federring 4			1
20	2759	Hexagon Nut M4	Sechskantmutter M4			1
21	303000041	Perforated plate 90x90	Lochblech 90x90			1

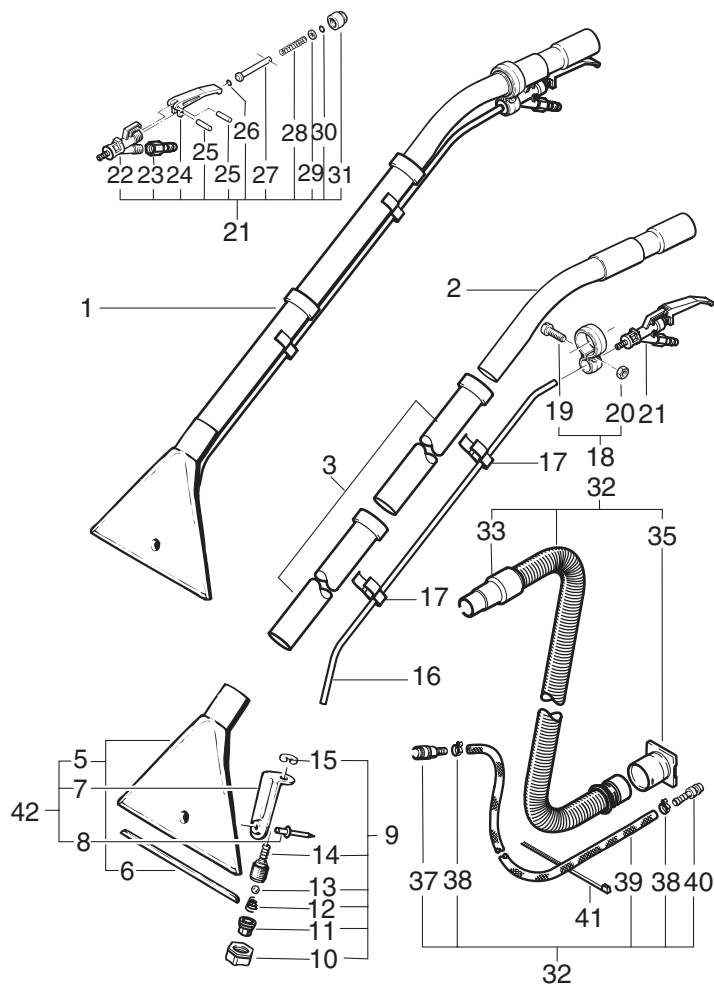

TW 400-106-S

Pos.	No.	Description	Bezeichnung	Comment Bemerkung Bemærkning	Rec. Part TW 400
1	303000045	Suction hose complete	Sprühextraktions-Set	consisting of Pos. 2-42	1
2	303000054	Curved Hand Tube DN32	Handrohr Gebogen DN32		1
3	15546	EXTEN TUBE Ø36 2x500MM SS	Saugrohr Ø36x1000 Set [2] VA		1
5	34473	Carpet Adaptor	Saugdüse		1
6	7245	Slide Rails for Carpet	Teppichgleitschiene		1
7	7247	Bracket	Halterung		1
8	15792	Rivet A4,8x16x15	Niet A4,8x16x15		1
9	34476	Spray Nozzle	Sprühdüsengarnitur		1
10	7365	Cap Nut G3/8"	Überwurfmutter G3/8"		1
11	7364	Nozzle	Sprühdüse		C 1
12	34477	Spring	Druckfeder		C 1
13	34478	Ball	Kugel		C 1
14	34479	Nozzle Holder	Düsenhalter		1
15	34480	Retaining Washer D9	Sicherungsscheibe D9		1
16	28090	Chemical Tube Ø6x1x1130	Sprühschlauch Ø6x1x1130		1
17	48375	Hose Clip	Schlauchhaltespange		2
18	7246	Pipe Clamp	Rohrschelle		1
19	3349	Screw M5x16	Zylinderschraube M5x16		1
20	2760	Hexagon Nut M5	Sechskantmutter M5		1
21	7379	Lever	Hebelventil		1
22	34482	Valve Body	Ventilkörper		C 1
23	7369	Coupler Nipple 1/4	Kupplungsniessel 1/4		1
24	7399	Lever	Ventilhebel		1
25	7401	Cylindrical Pin 1,5x14	Zylinderstift 1,5x14		2
26	32142	O-ring Ø5x2,5	O-Ring Ø5x2,5		1

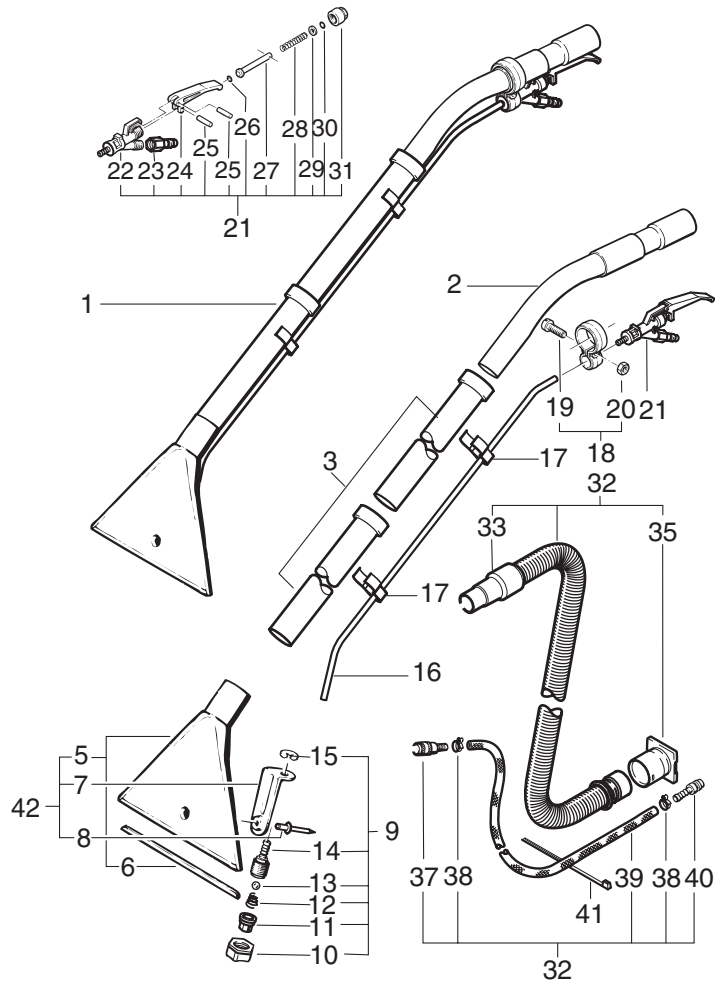

TW 400-106-S

Pos.	No.	Description	Bezeichnung	Comment Bemerkung Bemærkning	Rec. Part TW 400
27	7400	Valve Pin	Ventilstift		1
28	7370	Spring	Feder		1
29	2763	Washer 5,3x1	Scheibe 5,3x1		1
30	7368	O-ring Ø5x2	O-Ring Ø5x2		1
31	7371	Cap Nut G3/8"x19,2	Überwurfmutter G3/8"x19,2		1
32	303000048	Spray and suction hose kpl.	Sprüh-Saugschlauch kpl.		1
33	34487	Hose Sleeve Ø32	Muffe Ø32		1
35	303000052	Connector Ø32	Anschlussmuffe Ø32		1
37	7238	Coupling	Kupplung		1
38	7239	Hose Clip Ø14,5	Schlauchschelle Ø14,5		2
⇧	39	4973	Hose Ø6x3	Schlauch Ø6x3	1
40	7241	Nipple NW 8	Stecknippel NW 8		1
41	8819	Cable Strap 4,5x1x350	Kabelband 4,5x1x350		3
42	34472	Suction Nozzle	Saugdüse		1

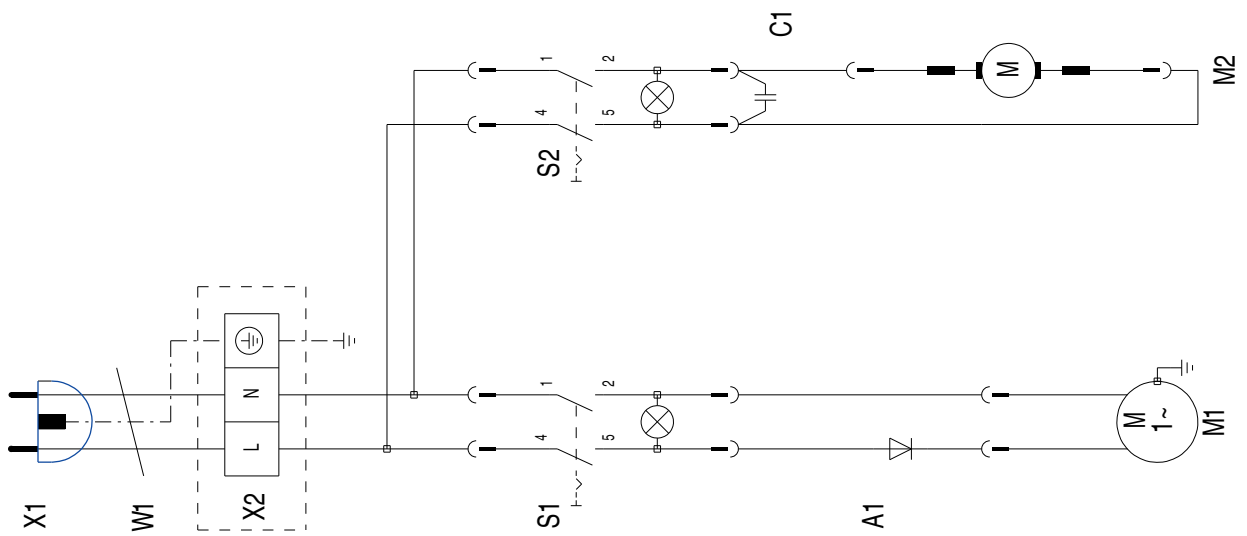

A1
C1
M1
M2
S1
S2
W1
X1
X2

Diode
Entstoerkondensator 0,15µF
Schwingkolbenpumpe
Saugmotor
Schalter fuer Schwingkolbenpumpe
Schalter fuer Saugmotor
Anschlussleitung
Anschlusstecker
Anschlussklemme

Diode
Decoupling capacitor
Pump
Vac motor
Pump switch
Vac motor switch
Power cord
Plug
Terminal







Nilfisk ALTO

Why Compromise

www.nilfisk-alto.com

HEADQUARTER

DENMARK

Nilfisk-Advance Group
Sognevej 25
2605 Brøndby
Denmark
Tel.: (+45) 43 23 81 00
Fax: (+45) 43 43 77 00
E-mail: mail@nilfisk-advance.dk

SALES COMPANIES

AUSTRALIA

Nilfisk-ALTO
48 Egerton St.
PO box 6046
Silverwater NSW 2128
Australia
Tel.: (+61) 2 8748 5966
Fax: (+61) 2 8748 5960

AUSTRIA

Nilfisk-Advance GmbH.
Nilfisk-ALTO
Metzgerstrasse 68
A-5101 Bergheim bei Salzburg
Tel.: (+43) 662 456 400-0
Fax: (+43) 662 456 400-34
E-mail: info@nilfisk-alto.at
www.nilfisk-alto.at

BRASIL

Wap do Brasil Ltda.
Rua das Palmeiras, 350
Capela Velha
83.705-500 – Araucária - PR
Brasil
Tel.: (+55) 41 2106 7400
Fax: (+55) 41 2106 7403
E-mail: export@wapdobrasil.com.br

CANADA

ALTO Canada
24 Constellation Road
Rexdale
Ontario M9W 1K1
Canada
Tel.: (+1) 416 675 5830
Fax: (+1) 416 675 6989

CZECH REPUBLIC

ALTO Česká republika s.r.o.
Zateckých 9
14000 Praha 4
Czech Republic
Tel.: (+420) 24 14 08 419
Fax: (+420) 24 14 08 439
E-mail: wap_p@mbox.vol.cz

DENMARK

Nilfisk-ALTO
Division of Nilfisk-Advance A/S
Industrivej 1
9560 Hadsund
Denmark
Tel.: (+45) 72 18 21 00
Fax: (+45) 72 18 21 11
E-mail: salg@nilfisk-alto.dk
E-mail: service@nilfisk-alto.dk
www.nilfisk-alto.dk

Nilfisk-ALTO Food Division
Division of Nilfisk-Advance A/S
Blytækkervej 2,
9000 Aalborg
Denmark
Tel.: (+45) 72 18 21 00
Fax: (+45) 72 18 20 99
E-mail: scanio.technology@nilfisk-alto.dk
www.nilfisk-alto.com

FRANCE

Nilfisk-ALTO
ALTO France SA
Aéroparc 1
19 rue Icare
67960 Entzheim
France
Tel.: (+33) 3 88 28 84 00
Fax: (+33) 3 88 30 05 00
E-mail: info@nilfisk-alto-fr
www.nilfisk-alto.com

GERMANY

Nilfisk-Advance AG
Nilfisk-ALTO Business Unit
Guido-Oberdorfer-Str. 10
89287 Bellenberg
Germany
Tel.: (+49) (0) 180 5 37 37 37
Fax: (+49) (0) 180 5 37 37 38
E-mail: info@nilfisk-alto.de
www.nilfisk-alto.de

HOLLAND

Nilfisk-ALTO
Division of Nilfisk-Advance BV
Camerastraat 9
NL-1322 BB Almere
Tel.: (+31) 36 5460 760
Fax: (+31) 36 5460 761
E-mail: info@nilfisk-alto.nl
www.nilfisk-alto.nl

HONG KONG

Nilfisk-Advance Ltd.
2001 HK Worsted Mills Ind'l Bldg.,
31-39 Wo Tong Tsui St.
Kwai Chung, Hong Kong
Tel.: (+852) 2427 5951
Fax: (+852) 2487 5828

HUNGARY

Kvantor-Itb Kft
II. Rákóczi Ferenc út 10
2310 Szigetszentmiklos-Lakihegy
Hungary
Tel.: (+36) 24 47 55 50
Fax: (+36) 24 47 55 51
E-mail: nilfisk@kvantor-itb.hu

JAPAN

Nilfisk-Advance, Inc.
1-6-6 Kita-shinyokohama, Kouhoku-ku,
Yokohama, 223-0059
Japan
Tel.: (+81) 45 548 2571
Fax: (+81) 45 548 2541

MALAYSIA

Nilfisk-Advance Sdn Bhd
No. 1011, Block A4
Leisure Commerce Square
No. 9, Jalan PJS 8/9
46150 Petaling Jaya
Selangor, Malaysia
Tel.: (+60) 3 603 7876 4222
Fax: (+60) 3 603 7876 3878

PEOPLE'S REPUBLIC OF CHINA

Nilfisk-Advance (Shenzhen) Ltd
Blok 3, Unit 130, 1001 Honghua Road
Int. Commercial & Trade Center
Fuitian Free Trade Zone
518038 Shenzhen
P.R. China
Tel.: (+86) 755 8359 7937
Fax: (+86) 755 8359 1063

POLAND

Nilfisk-ALTO
Division of Nilfisk-Advance A/S
05-800 Pruszków
ul. 3-go MAJA 8
Poland
Tel.: (+48) 22 738 37 50
Fax: (+48) 22 738 37 51
info@nilfisk-alto.pl
www.nilfisk-alto.pl

NORWAY

ALTO Norge AS
Bjørnerudveien 24

1266 Oslo
Norway
Tel.: (+47) 22 75 17 70
Fax: (+47) 22 75 17 71
E-mail: info@nilfisk-alto.no
www.nilfisk-alto.no

PORTUGAL

Nilfisk-ALTO
Division of Nilfisk-Advance Lda.
Sintra Business Park
Zona Industrial Da Abrunheira
Edificio 1, 1º A
P-2710-089 Sintra
Tel.: (+35) 808 200 537
Fax: (+35) 121 911 2679
E-mail: mkt@nilfisk-advance.es
www.nilfisk-alto.com

SINGAPORE

Nilfisk-Advance Pte. Ltd.
Nilfisk-ALTO Division
40 Loyang Drive
Singapore 508961
sales@nilfisk-advance.com.sg
Tel.: (+65) 6 759 9100
Fax: (+65) 6 759 9133

SPAIN

Nilfisk-ALTO
Division of Nilfisk-Advance S.A.
Torre DAra
Paseo del Rengle, 5 Pl. 10
E-08302 Mataró
Tel.: (+34) 902 200 201
Fax: (+34) 93 757 8020
E-mail: mkt@nilfisk-advance.es
www.nilfisk-alto.com

SWEDEN

ALTO Sverige AB
Member of Nilfisk-Advance Group
Aminogatan 18, Box 4029
S-431 04 Mölndal
Sweden
Tel.: (+46) 31 706 73 00
Fax: (+46) 31 706 73 40
E-mail: info@nilfisk-alto.se
www.nilfisk-alto.se

TAIWAN

Nilfisk-Advance Ltd.
Taiwan Branch (H.K.)
1F, No. 193, Sec.2
Xing Long Rd., Taipei
Taiwan, R.O.C.
Tel.: (+886) 2 2239 8812
Fax: (+886) 2 2239 8832

THAILAND

Nilfisk-Advance Co. Ltd.
89 Soi Chokechai-Ruammitr
Viphavadee-Rangsit Road
Ladyao, Jatuchak, Bangkok 10900
Thailand
Tel.: (+66) 2 275 5630
Fax: (+66) 2 691 4079

UNITED KINGDOM

Nilfisk-ALTO
Division of Nilfisk-Advance Ltd.
Bowerbank Way
Gilwilly Industrial Estate
Penrith Cumbria CA11 9BQ
Great Britain
Tel.: (+44) (0) 1768 868995
Fax: (+44) (0) 1768 864713
E-mail: sales@nilfisk-alto.co.uk
www.nilfisk-alto.co.uk

USA

ALTO Cleaning Systems Inc.
Part of the Nilfisk-Advance Group
12249 Nations Ford Road
Pineville, NC 28134
USA
Tel.: (+1) 704 971 1240
Fax: (+1) 704 971 1241
E-mail: info@nilfisk-advance.us
www.nilfisk-alto.com