

AERO 400
AERO 440
AERO 640
AERO 840 A
AERO 5 Gallon
AERO 7 Gallon AS/E

ALTO[®]
Why
Compromise[™]



Spare parts
Ersatzteile
Pièces détachées
Reservedele

Zeichenerklärung

Key to symbols

Légende

Symbol erklæring

Recommended spare parts

A-Parts:

Wearing parts. The recommended stock size is: [Number of machines x 1.2 x years] or min. 1.

These parts are typical: Suction and cooling air filters, filter bags, disposal bags, etc.

B-Parts:

Heavy used parts. The recommended stock size is: [Number of machines x 0.6 x years] or min. 1.

These parts are typical: Motor, carbon brushes, floor nozzles, crevice nozzles, power cable, etc.

C-Parts:

Important parts to run the machine. The recommended stock size is: [Number of machines x 0.1 x years] or min. 1.

These parts are typical: Electrical parts, switches, electronic boards, flow sensor, sockets, contact spring, clamps, wheels, handles, etc.

Empfohlene Ersatzteile

A-Teile:

Verschleissteile. Empfohlene Lagerstückzahl: [Anzahl der Maschinen x 1,2 x Jahre] oder min. 1.

Diese Teile sind typisch: Saug- und Luftfilter, Filtertüten, Entsorgungssäcke, etc.

B-Teile:

Schwer beanpruchte Teile. Empfohlene Lagerstückzahl: [Anzahl der Maschinen x 0,6 x Jahre] oder min. 1.

Diese Teile sind typisch: Motoren, Kohlebürsten, Bodendüsen, Netzleitung, Fugendüsen, etc.

C-Teile:

Zum Betrieb der Maschine wichtige Teile. Empfohlene Lagerstückzahl: [Anzahl der Maschinen x 0,1 x Jahre] oder min. 1.

Diese Teile sind typisch: Elektrische Teile, Schalter, Platinen, Strömungswächter, Kontaktfedern, Steckdosen, Klammern, Räder, Handgriff, etc.

Liste de pièces à stocker :

Pièces-A:

Pièces d'usure. Le stock conseillé est : [nombre de machines x 1.2 x années] avec un minimum de 1.

Classiquement, ces pièces sont: Filtres d'aspiration et de refroidissement d'air, sacs filtre, sacs à déchets, etc...

Pièces-B:

Pièces fortement sollicitées. Le stock conseillé est : [nombre de machines x 0.6 x années] avec un minimum de 1.

Classiquement, ces pièces sont: Moteur, balais, buses de nettoyage de sol, câble électrique, etc...

Pièces-C:

Pièces nécessaires au fonctionnement. Le stock conseillé est : [nombre de machines x 0.1 x années] avec un minimum de 1.

Classiquement, ces pièces sont: Elements électriques, interrupteurs, circuits imprimés, capteur de flux, prises, ressort de contact, agrafes, roues, poignées, etc...

Anbefalede reservedele

A-Parts:

Sliddele. Anbefalet lagerstørrelse: [Antal maskiner x 1,2 x år] eller min. 1.

Disse dele er typisk: Suge- og køle luftfiltre, filterposer, affaldsposer m.v.

B-Parts:

Hårdt belastede dele. Anbefalet lagerstørrelse: [Antal maskiner x 0,6 x år] eller min. 1.

Disse dele er typisk: Motor, kulbørster, gulvdyser, sugemundstykke til sprækker, el-ledning m.v.

C-Parts:

Vigtige dele for at maskinen kører. Anbefalet lagerstørrelse: [Antal maskiner x 0,1 x år] eller min. 1.

Disse dele er typisk: Elektriske dele, kontakter, printkort, flow føler, stikdåser, kontaktfjeder, spændestykker, hjul, håndtag m.v.

- ❖ ACHTUNG! - Meterware - Bitte bei Bestellung gewünschte Länge angeben!
ATTENTION! - Lengths in metres - Please indicate required length when ordering!
ATTENTION! - Longueurs par mètre - Préciser la longueur à la commande!
BEMÆRK! - Metervare - Ved bestilling venligst opgive den ønskede længde!

- | | |
|-----------------|--------------|
| * bestehend aus | ● beinhaltet |
| consisting of | includes |
| composé de | inclus |
| bestående af | inkludere |

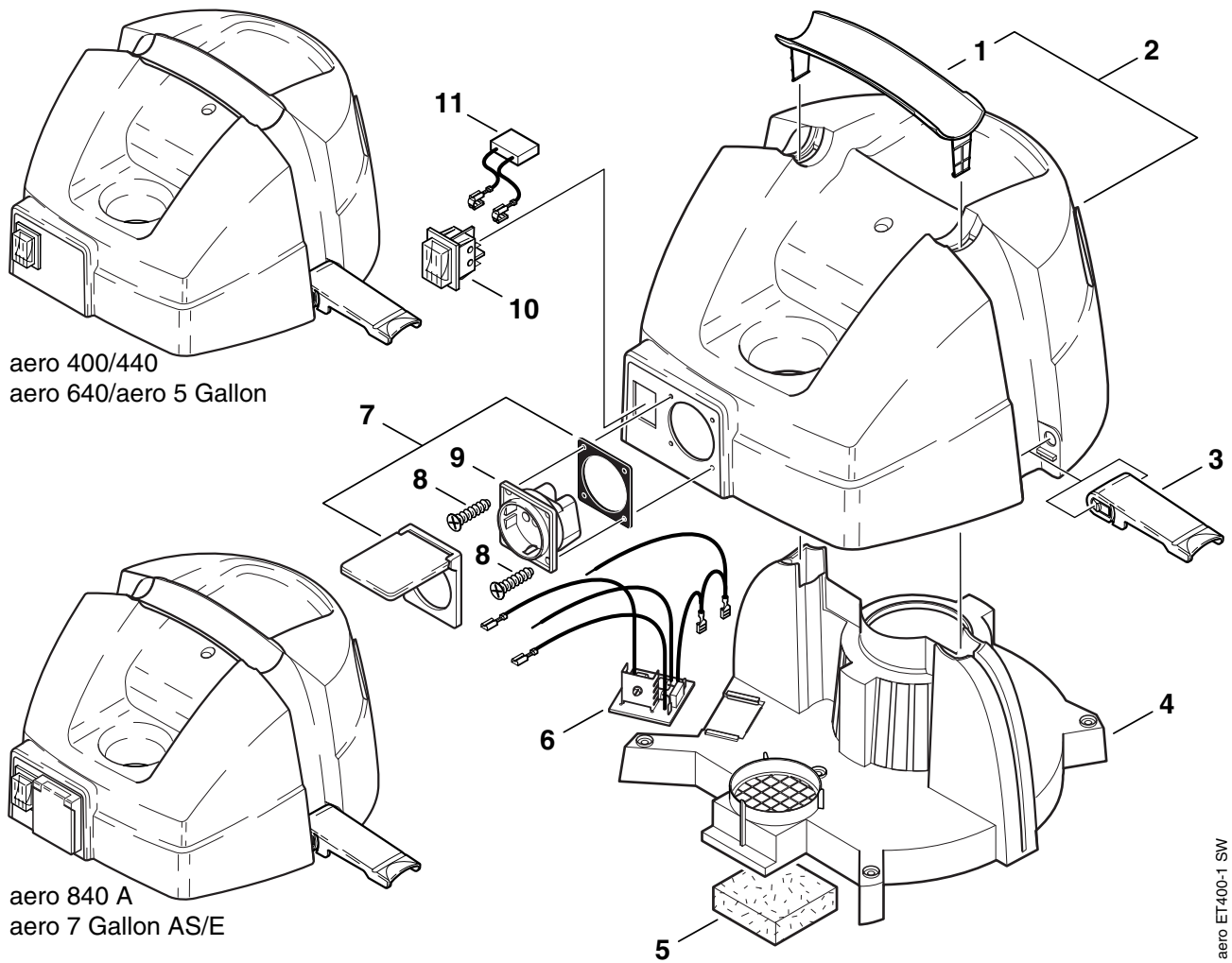

aero ET400-1 SW

Pos.	No.	Description	Bezeichnung	Désignation	Betegnelse	Comment Bemerkung Remarque Bemærkning	Rec. Part	AERO
1	60603	Handle	Griff	Poignée	Håndtag		C	1
2	63569	Cover w. handle	Haube mit Griff	Capot avec Poignée	Kappe med håndtag	aero 400	C	1
2	63570	Cover w. handle	Haube mit Griff	Capot avec Poignée	Kappe med håndtag	mit Schalldämmung, aero 440, 640, aero 5 Gallon	C	1
2	63572	Cover w. handle	Haube mit Griff	Capot avec Poignée	Kappe med håndtag	mit Schalldämmung, aero 840 A, aero 7 Gal- lon AS/E	C	1
3	26797	Locking clamp	Klammer	Crochet de fermeture	Lukkeklamme		B	2
4	60604	Supporting plate	Spannplatte	Plateau de serrage	Spændeplade	aero 400	C	1
4	62262	Supporting plate	Spannplatte	Plateau de serrage	Spændeplade	mit Schalldämmung, aero 440, 640, 840 A, aero 5 Gallon,, aero 7 Gallon AS/E	C	1
5	60611	Diffusor	Diffusor	Diffuseur	Diffusor		A	1
6	61278	Automatic ON/OFF system 100-240V	Einschaltautomatik 100-240V Set	Interrupcteur automatique 100-240V	Automatic ON/OFF system 100-240V	aero 840 A	C	1
6	62171	Automatic ON/OFF system 100-120V	Einschaltautomatik 100-120V	Interrupcteur automatique 100-120V	Automatic ON/OFF system 100-120V	aero 840 A *US*JP*TW*,aero 7 Gal- lon AS/E	C	1
7	63851	Hinged cover frame	Abdeckrahmen mit Klappdeckel	Cache	Stikdåse afdækning	aero 840 A*EU*KR*CH* GB,230V*ZA*US*TW*J P*, aero 7 Gallon AS/E	B	1
8	11254	Screw EJOT- KA35x10	Schraube EJOT- KA35x10	Vis EJOT- KA35x10	Skrue EJOT- KA35x10	aero 840 A*EU*KR*CH* GB,230V*ZA*US*TW*J P*, aero 7 Gallon AS/E	C	2
9	46296	Socket *DE*	Steckdose Schuko	Prise électrique *DE*	Stikkontakt *DE*	aero 840 A *EU*KR*ZA*	C	1
9	48278	Socket *GB*	Steckdose *GB*	Prise électrique *GB*	Stikkontakt *GB*	aero 840 A *GB,230V*	C	1
9	48287	Socket *CH*	Steckdose *CH*	Prise électrique *CH*	Stikkontakt *CH*	aero 840 A *CH*	C	1

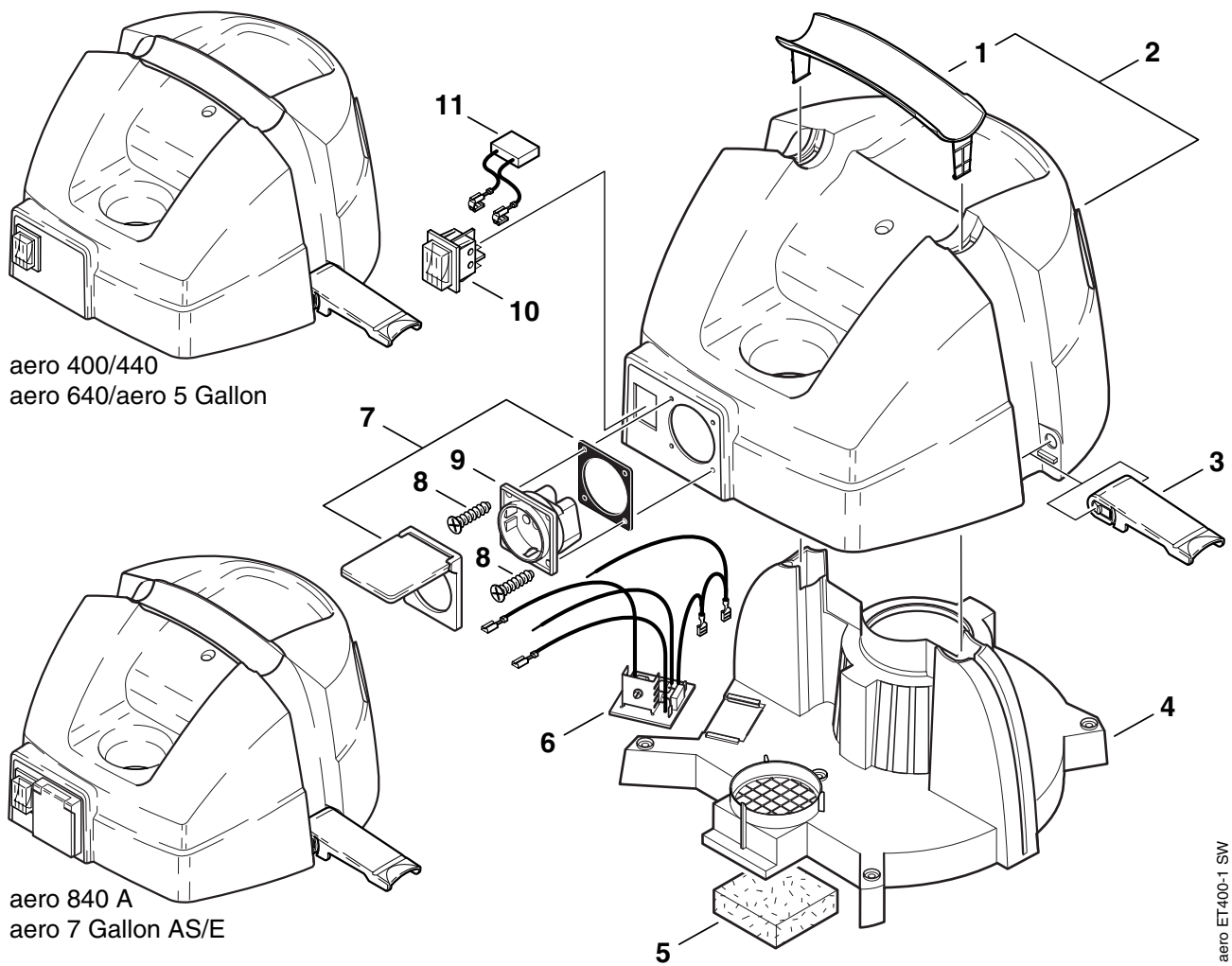

Pos.	No.	Description	Bezeichnung	Désignation	Betegnelse	Comment Bemerkung Bemærkning	Rec. Part	AERO
9	49267	Socket *USA/CDN*	Steckdose *USA/CDN*	Prise électrique *USA/CDN*	Stikkontakt *USA/CDN*	aero 840 A *US*TW*JP* aero 7 Gallon AS/E	C	1
9	64079	Socket *DK*	Steckdose *DK*	Prise électrique *DK*	Stikkontakt *DK*	aero 840 A *DK*	C	1
10	11992	Switch	Schalter	Interrupteur	Afbryder	aero 840 A, aero 7 Gallon AS/E	C	1
10	60867	Switch	Schalter	Interrupteur	Afbryder	aero 400, 440, 640, aero 5 Gallon	C	1
11	61385	Interference suppression capacitor 0.1µF	Entstörkondensator 0,1µF	Condensateur 0,1µF	Undertrykkeses kondensator 0,1µF	aero 400, 440 *EU*CH*GB,230V*, aero 640 *EU*CH*GB,230V*, aero 840 A *EU*CH*GB,230V*	C	1

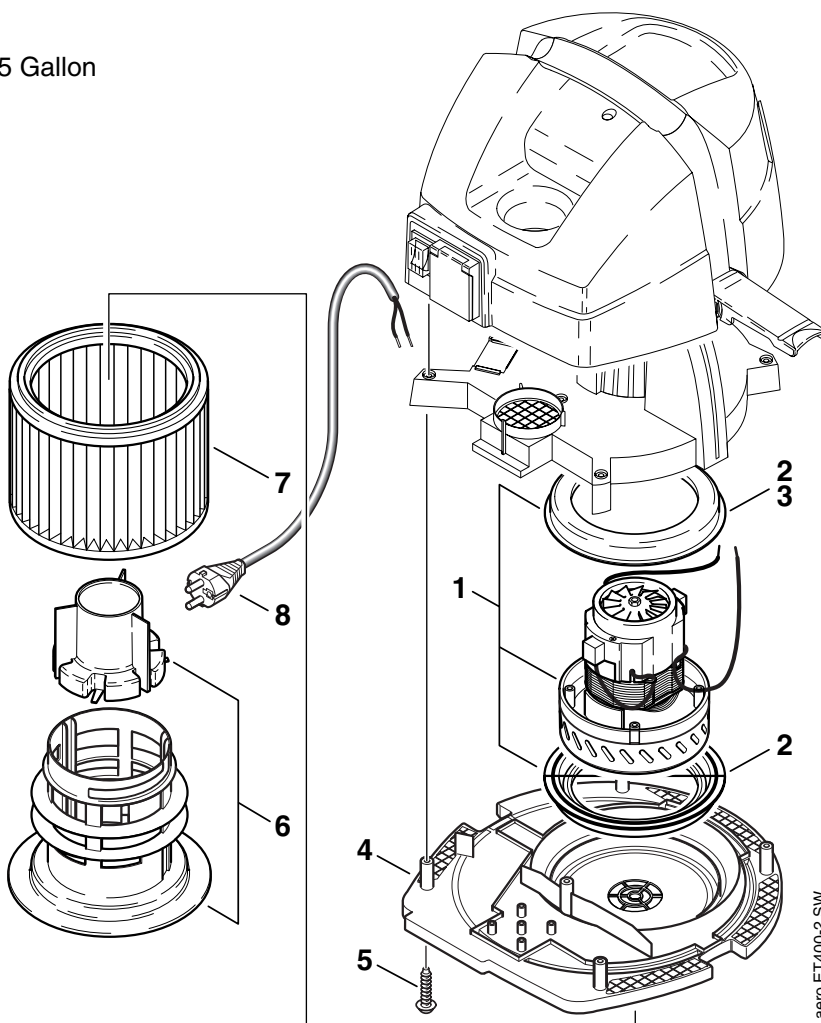
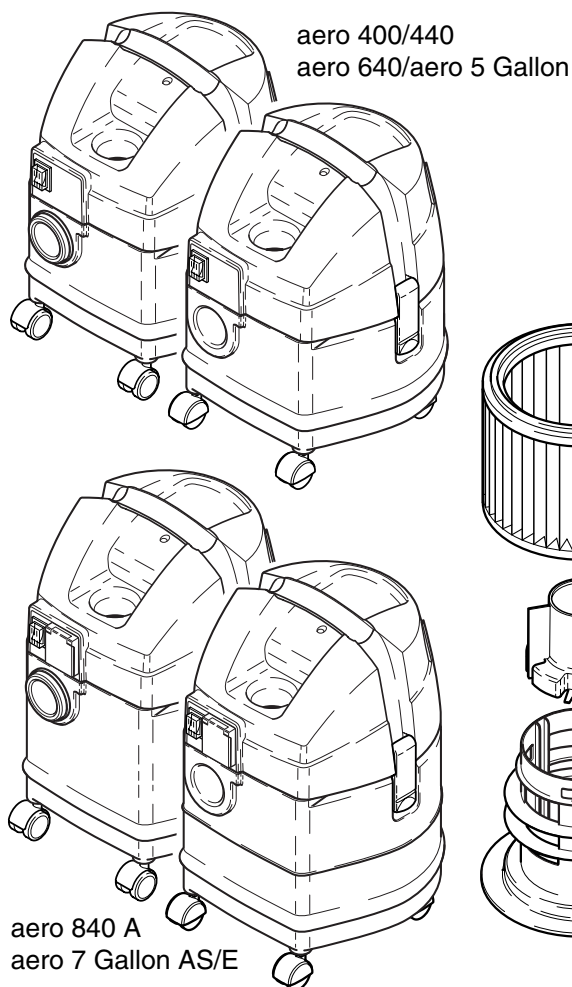

Pos.	No.	Description	Bezeichnung	Désignation	Betegnelse	Comment Bemerkung Bemærkning	Rec. Part	AERO
1	60932	Motor 100V 1000W	Motor 100V 1000W	Moteur 100V 1000W	Motor 100 V 1000W	*JP*	B	1
1	60933	Motor 120 V 1000W	Motor 120 V 1000W	Moteur 120 V 1000W	Motor 120 V 1000W	*US*TW*GB,110V*	B	1
1	60934	Motor 230 V 1000W	Motor 230 V 1000W	Moteur 230 V 1000W	Motor 230 V 1000W	*EU*KR*CH*GB,230V* *ZA*	B	1
2	60610	Motor bearing ring	Motorlagerring	Jeu d'anneaux de palier	Motorlejerings	bei Kennbuchstabe "O", for identif.letter "O", pour lettre d'ident."O", ved bogstav "O"	B	1
3	302000364	Motor bearing ring ø137,5xø162x17	Motorlagerring ø137,5xø162x17	Jeu d'anneaux de palier ø137,5xø162x17	Motorlejerings ø137,5xø162x17	bei Kennbuchstabe "P", for identif.letter "P", pour lettre d'ident."P", ved bogstav "P"	B	1
4	60605	Base	Trägerplatte	Plaque de support	Bæreplade	aero 400	C	1
4	62260	Base	Trägerplatte	Plaque de support	Bæreplade	mit Schalldämmung, aero 440, 640, 840A, aero 5 Gallon, aero 7 Gallon AS/E	C	1
5	11253	Screw EJOT- KA50x20 WN 1413	Schraube EJOT- KA50x20 WN 1413	Vis EJOT- KA50x20 WN 1413	Skrue EJOT- KA50x20 WN 1413		C	4
6	63575	Filter supporting basket with float	Filterstützkorb m.Schwimmer	Corbeille de filtre	Filterstøttekurv		C	1
7	63990	Filter element Set	Filterelement ET-Set	Cartouche filtrante Set	Filterelement Set		A	1
8	26771	Power cord H05VV- F2x1,0x 7,5	Netzleitung H05VV- F2x1,0x 7,5	Câble alim H05VV- F2x1,0x 7,5	Ledning H05VV-F2x1,0x 7,5	aero 400, 440, 640 *EU*KR*	B	1
8	26902	Power cord H05VV- F2x1,0x7,5*GB*	Netzleitung H05VV- F2x1,0x7,5*GB*	Câble alim H05VV- F2x1,0x7,5*GB*	Ledning H05VV- F2x1,0x7,5*GB*	aero 400, 440, 640, *GB,230V*	B	1
8	29126	Power cord SJTW2xAWG18x6,7	Netzleitung SJTW2xAWG18x6,7	Câble alim SJTW2xAWG18x6,7	Ledning SJTW2xAWG18x6,7	aero 400, 440, 640, *US*TW*JP*, aero 5 Gallon	B	1

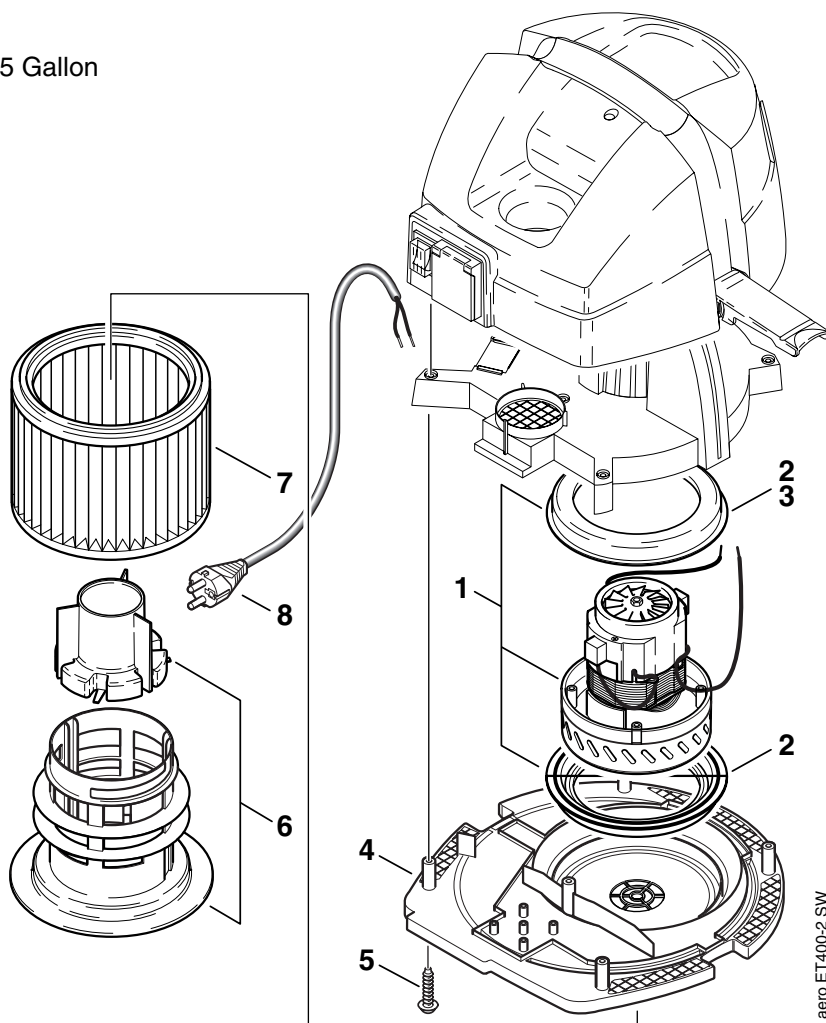
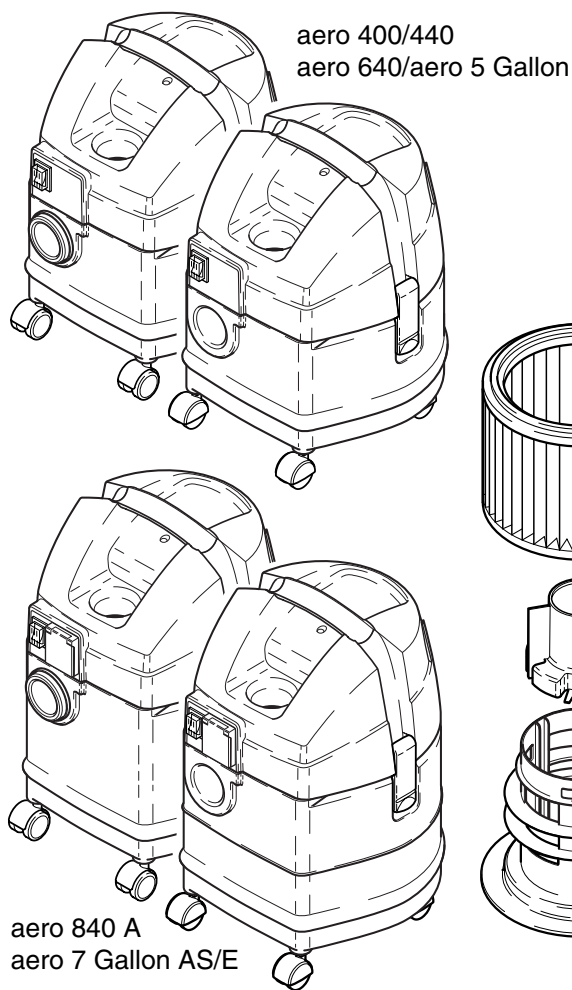

aero ET400-2 SW

Pos.	No.	Description	Bezeichnung	Désignation	Betegnelse	Comment Bemerkung Bemærkning	Rec. Part	AERO
8	29466	Power cord H05VV-F2x1,0x7,5	Netzleitung H05VV-F2x1,0x7,5	Câble alim H05VV-F2x1,0x7,5	Ledning H05VV-F2x1,0x7,5	aero 400, 440, 640, *CH*	B	1
8	60282	Power cord NGMH11YÖ2x1,5²x7,5	Netzleitung NGMH11YÖ2x1,5²x7,5	Câble alim NGMH11YÖ2x1,5²x7,5	Ledning NGMH11YÖ2x1,5²x7,5	aero 400, 440, *GB,110V*	B	1
8	60903	Power cord H05VV-F2x0,75x5,0 SABS	Netzleitung H05VV-F2x0,75x5,0 SABS	Câble alim H05VV-F2x0,75x5,0 SABS	Ledning H05VV-F2x0,75x5,0 SABS	aero 400, 440, 640 *ZA*	B	1
8	61129	Power cord H05VV-F3G1,5x5,0	Netzleitung H05VV-F3G1,5x5,0	Câble alim H05VV-F3G1,5x5,0	Ledning H05VV-F3G1,5x5,0	aero 840 A *GB,230V*	B	1
8	61130	Power cord H05VV-F3G1,5x5,0	Netzleitung H05VV-F3G1,5x5,0	Câble alim H05VV-F3G1,5x5,0	Ledning H05VV-F3G1,5x5,0	aero 840 A *EU*KR*	B	1
8	61131	Power cord H05VV-F3G1,5x5,0	Netzleitung H05VV-F3G1,5x5,0	Câble alim H05VV-F3G1,5x5,0	Ledning H05VV-F3G1,5x5,0	aero 840 A *ZA*	B	1
8	61132	Power cord H05VV-F3G1,5x5,0	Netzleitung H05VV-F3G1,5x5,0	Câble alim H05VV-F3G1,5x5,0	Ledning H05VV-F3G1,5x5,0	aero 840 A *CH*	B	1
8	61133	Power cord SJTW3AWG16x6,7 NEMA	Netzleitung SJTW3AWG16x6,7 NEMA	Câble alim SJTW3AWG16x6,7 NEMA	Ledning SJTW3AWG16x6,7 NEMA	aero 840 A *US*TW*JP*, aero 7 Gallon AS/E	B	1
8	64165	Power cord H05VV-F3G1,5x5,0	Netzleitung H05VV-F3G1,5x5,0	Câble alim H05VV-F3G1,5x5,0	Ledning H05VV-F3G1,5x5,0	aero 840 A *DK*	B	1

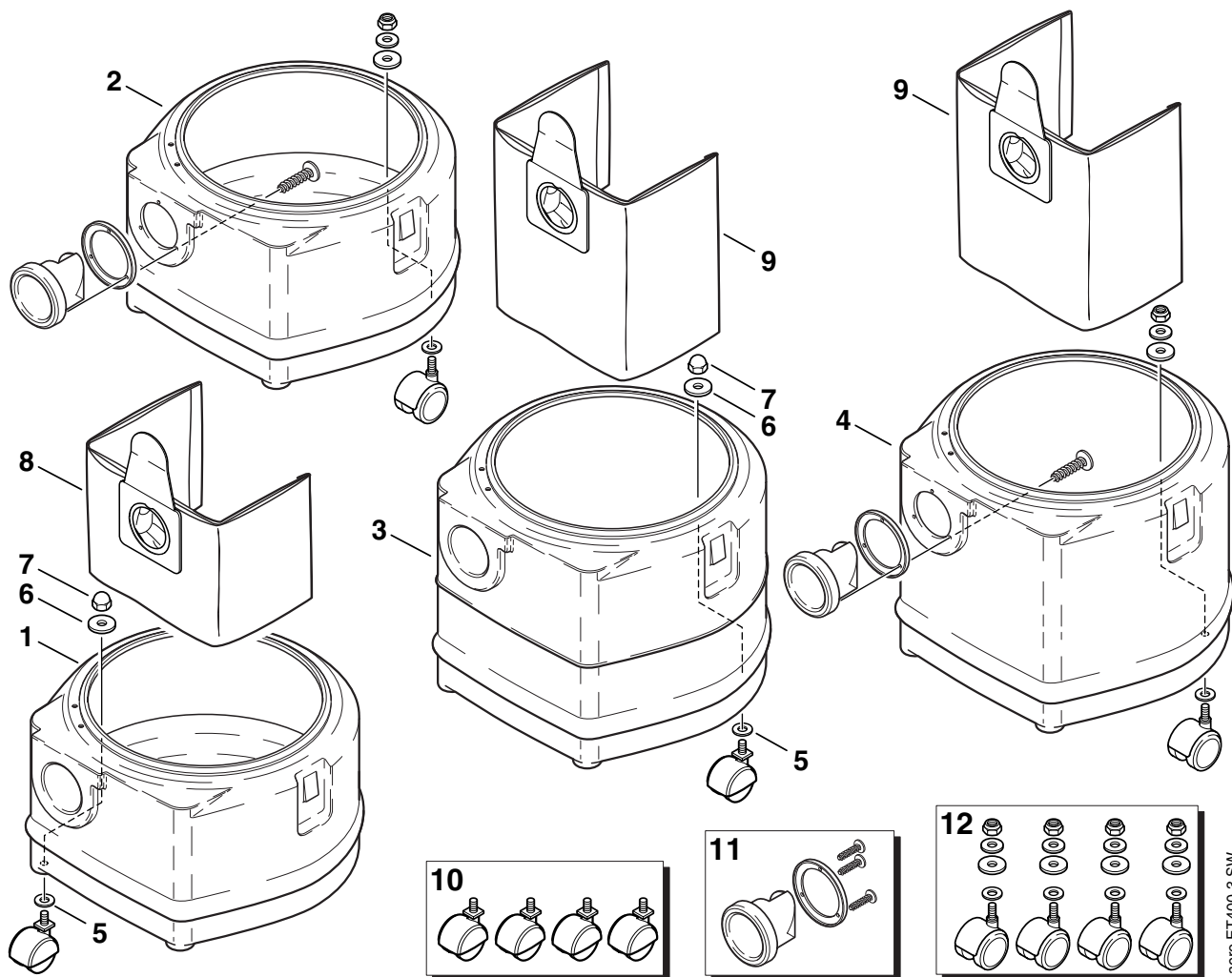

aero ET400-3 SW

Pos.	No.	Description	Bezeichnung	Désignation	Betegnelse	Comment Bemerkung Bemærkning	Rec. Part	AERO
1	65250	Container aero 400	Behälter aero 400	Réservoir aero 400	Beholder aero 400		C	1
1	65252	Container aero 440, aero 5 Gallon	Behälter aero 440, aero 5 Gallon	Réservoir aero 440, aero 5 Gallon	Beholder aero 440, aero 5 Gallon		C	1
2	302000938	Container aero 400	Behälter aero 400	Réservoir aero 400	Beholder aero 400		C	1
2	302000939	Container aero 440, aero 5 Gallon	Behälter aero 440, aero 5 Gallon	Réservoir aero 440, aero 5 Gallon	Beholder aero 440, aero 5 Gallon		C	1
3	65256	Container aero 640	Behälter aero 640	Réservoir aero 640	Beholder aero 640		C	1
3	65260	Container aero 840A, aero 7 Gallon AS/E	Behälter aero 840A, aero 7 Gallon AS/E	Réservoir aero 840A, aero 7 Gallon AS/E	Beholder aero 840A, aero 7 Gallon AS/E		C	1
4	302000940	Container aero 640	Behälter aero 640	Réservoir aero 640	Beholder aero 640		C	1
4	302000941	Container aero 840A, aero 7 Gallon AS/E	Behälter aero 840A, aero 7 Gallon AS/E	Réservoir aero 840A, aero 7 Gallon AS/E	Beholder aero 840A, aero 7 Gallon AS/E		C	1
5	61276	Sealing washer ø8,5xø18x1	Dichtscheibe ø8,5xø18x1	Rondelle ø8,5xø18x1	Skive ø8,5xø18x1		B	1
6	2793	Washer 8,4x2 A ISO7093	Scheibe 8,4x2 A ISO7093	Rondelle 8,4x2 A ISO7093	Skive 8,4x2 A ISO7093		C	1
7	2364	Cap nut M8	Mutter Hut- M8	Ecrou M8	Møtrik M8		C	1
8	61156	Filter bag set-5	Filtersack Set (5St)	Sac-filtre kit-5	Filterpose Set-5	aero 400, 440, aero 5 Gallon	A	1
9	60910	Filter bag set-5	Filtersack Set (5St)	Sac-filtre kit-5	Filterpose Set-5	aero 640, 840 A, aero 7 Gallon AS/E	A	1
10	60608	Guide roller set	Lenkrollen-Set (4 St)	Galet de guidage	Styrerulle		B	1
11	302000942	Fitting DN 50	Einlassfitting DN 50	Raccord DN 50	Fitting DN 50		C	1
12	302000943	Guide roller set (4)	Lenkrollen-Set (4St)	Galet de guidage (4)	Styrerulle-Set (4)		B	1

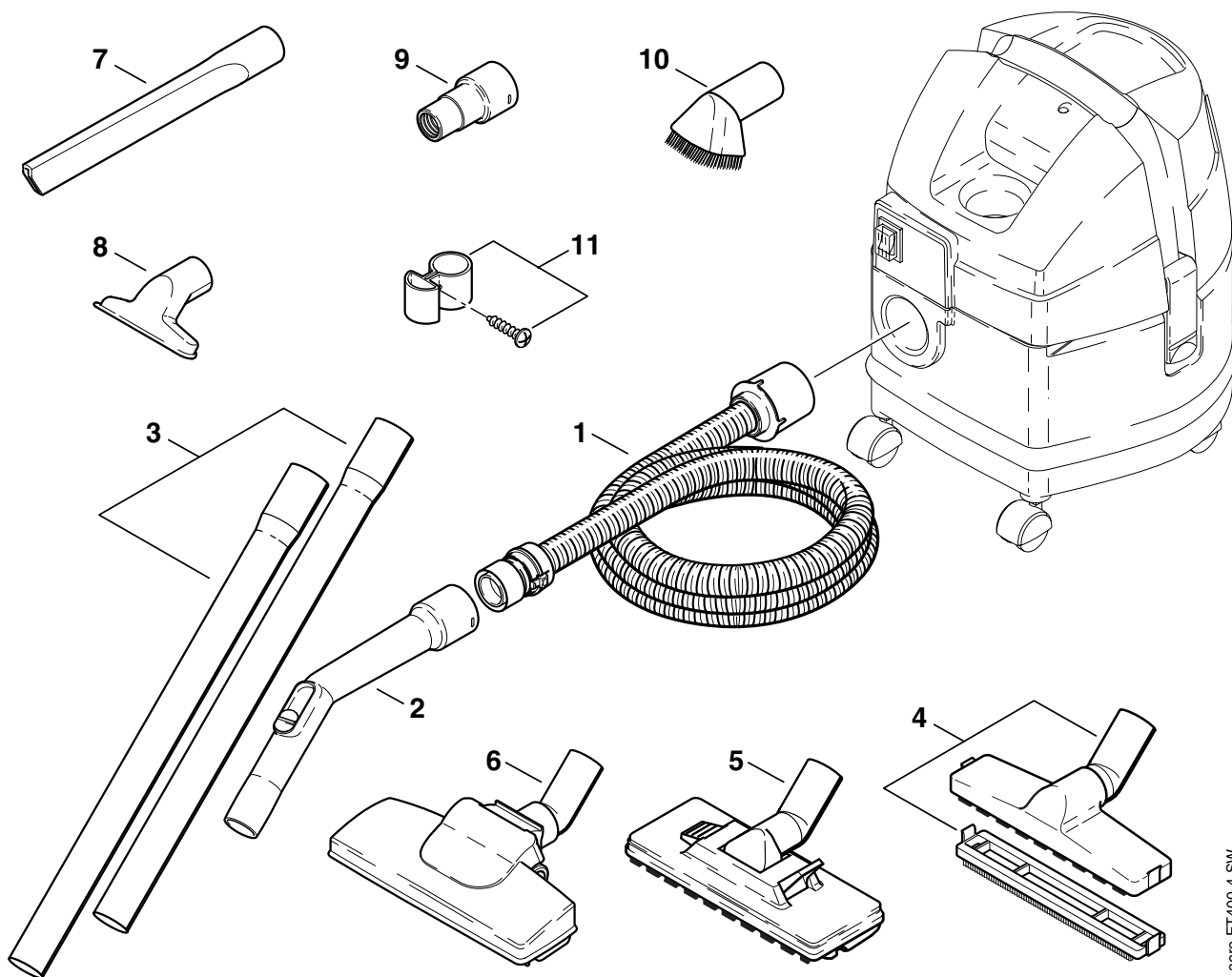

aero ET400-4 SW

Pos.	No.	Description	Bezeichnung	Désignation	Betegnelse	Comment Bemerkung Bemærkning	Rec. Part AERO
1	60897	Suction hose ø32x1800mm	Saugschlauch ø32x1800mm	Flexible d'aspirationø32x1800mm	Sugeslange ø32x1800mm		B
1	64187	Suction hose ø32x3500mm	Saugschlauch ø32x3500mm	Flexible d'aspiration ø32x3500mm	Sugeslange ø32x3500mm		B
2	60911	Curved hand tube ø32/ø35	Handrohr geb. ø32/ø35	Manche coudé ø32/ø35	Griberør bøjet ø32/ø35		B
3	15546	Extension tube VA	Verlängerungsrohr 2- teilig VA	Tuyau de rallonge VA	Lige rør VA		B
3	40696	Extension tube PVC	Verlängerungsrohr 2- teilig PVC	Tuyau de rallonge PVC	Lige rør PVC		B
3	302000478	Extension tube Alu	Verlängerungsrohr 2- teilig Alu	Tuyau de rallonge Alu	Lige rør Alu		B
4	60908	Floor nozzle	Bodendüse	Outil de solo	Floor nozzle		B
5	8046	Combination nozzle ø36	Combi-Düse ø36	Buse combinée ø36	Kombidyse ø36		B
6	62352	Vario floor nozzle	Vario-Bodendüse ø 36	Brosse	Vario-dyse		B
7	6084	Crevice nozzle ø35x300	Fugendüse ø35x300	Suceur pour rainures ø35x300	Fugemundstykke ø35x300		B
7	29541	Crevice nozzle ø35x200	Fugendüse ø35x200	Suceur pour rainures ø35x200	Fugemundstykke ø35x200		B
8	14295	Universal nozzle	Universaldüse	Buse universelle	Universalmundstykke		B
9	60916	Tool socket ø27/35/38	Werkzeugmuffe ø27/ 35/38	Raccord d'outil ø27/35/38	Værktøjsmuffe ø27/35/38		B
10	5146	Suction brush ø 36	Saugpinsel ø 36	Pinceau aspiration ø 36	Suction brush ø 36		B
11	60609	Tube holder	Rohrhalter	Support tube	Holder		C







**INTERNET**

<http://www.alto-online.com>

ALTO HEADQUARTERS

Incentive International A/S
Kongens Nytorv 28
P.O.Box 2064
1013 Copenhagen K
Tel.: +45 72 18 10 00
Fax: +45 72 18 1164
E-mail: incentive@incentive-dk.com

SUBSIDIARIES**AUSTRALIA**

ALTO Overseas Inc.
1B/8 Resolution Drive
P.O.Box 797
Caringbah, N.S.W. 2229
Tel.: +61 2 95 24 61 22
Fax: +61 2 95 24 52 56

AUSTRIA

ALTO Österreich GmbH
Metzgerstr. 68
5101 Bergheim/Salzburg
Tel.: +43 6624 5 64 00-14
Fax: +43 6624 5 64 00-55
E-mail: wap@salzburg.co.at

BRAZIL

Wap do Brasil Ltda.
Rua 25 de Agosto, 608
83323-260 Pinhais/Paraná
Tel.: +55 4 12 10 67 40 0
Fax: +55 4 12 10 67 40 3
E-mail: wap@wapdobrazil.com.br

CANADA

ALTO Canada
24 Constellation Road
Rexdale
Ontario M9W 1K1
Tel.: +1 416 6 75 58 30
Fax: +1 416 6 75 69 89

CROATIA

Wap ALTO Strojevi za čišćenje, d.o.o.
Siget 18a
10020 Zagreb
Tel.: +385 1 65 54 144
Fax: +385 1 65 54 112
E-mail: admin.wap@wap-sistemi.hr

CZECH REPUBLIC

ALTO Česká Republika s.r.o.
Zateckých 9
14000 Praha 4
Tel.: +420 2 41 40 84 19
Fax: +420 2 41 40 84 39
E-mail: wap_p@mbox.vol.cz
Web: www.wap-alto.cz

DENMARK

ALTO Danmark A/S
Industriksvarteret
9560 Hadsund
Tel.: +45 7218 21 00
Fax: +45 7218 21 05
E-mail: salg@alto-dk.com

FRANCE

ALTO France S.A.
B.P. 44, 4 Place d'Ostwald
67036 Strasbourg Cedex 2
Tel.: +33 3 88 28 84 00
Fax: +33 3 88 30 05 00
E-mail: info@alto-fr.com

GERMANY

ALTO Deutschland GmbH
Guido-Oberdorfer-Straße 2-8
89287 Bellenberg
Tel.: +49 0180 5 37 37 37
Fax: +49 0180 5 37 37 38
E-mail: info@wap-online.de

GREAT BRITAIN

ALTO Cleaning Systems
(UK) Ltd.
Bowerbank Way
Gilwilly Industrial Estate, Penrith
Cumbria CA11 9BN
Tel.: +44 1 7 68 86 89 95
Fax: +44 1 7 68 86 47 13
E-mail: sales@alto-uk.com

NETHERLANDS

ALTO Nederland B.V.
Postbus 65
3370 AB Hardinxveld-
Giessendam
Tel.: +31 18 46 77 20 0
Fax: +31 18 46 77 20 1
E-mail: info@alto-nl.com

NEW ZEALAND

ALTO Overseas Inc.
5A Tarndale Grove
Albany Auckland
Tel.: +64 9 414 4520
Fax: +64 9 414 4521
E-mail: altonz@ihug.co.nz

NORWAY

ALTO Norge A/S
Bjørnerudveien 24
1266 Oslo
Tel.: +47 22 75 17 70
Fax: +47 22 75 17 71
E-mail: info@alto-no.com

SINGAPORE

ALTO DEN-SIN Singapore Pte Ltd.
No. 17 Link Road
Singapore 619034
Tel.: +65 62 68 10 06
Fax: +65 62 68 49 16
E-mail: densin@singnet.com.sg
Web: www.densin.com

SLOVENIA

Wap ALTO čistilni sistemi, d.o.o.
Letališka 33
SLO-1110 Ljubljana
Tel.: +368 15 20 62 00
Fax: +368 15 20 62 10
E-mail: wap@siol.net

SLOWAKIA

Wap ALTO čistiace systémy s.r.o.
Remeselnícka 42
83106 Bratislava-Rača
Tel.: +421 2 44 881 402
Fax: +421 2 44 881 395
E-mail: wap@gtinet.sk
Web: www.wap-alto.sk

SPAIN

ALTO Ibérica, S.L.
Torre Europa
Paseo de la Castellana, 95
Planta 15
28046 Madrid
Tel.: +34 902 36 21 24
Fax: +34 914 18 69 99
E-mail: info@alto-es.com

SWEDEN

ALTO Sverige AB
Aminogatan 18
431 04 Mölndal
Tel.: +46 3 17 06 73 00
Fax: +46 3 17 06 73 41
E-mail: info@alto-se.com

USA

ALTO Cleaning Systems, Inc.
12249 Nations Ford Road
28134 Pineville
Tel.: +1 704 971 1240
Fax: +1 704 971 1241
E-mail: info@altocsi.com